

# ***TABLE EXAMPLES.***

VALUABLE ADVICE AND CHECKPOINTS WHEN PLANNING AN ORDERING TABLING FOR A GRANULE COMBI® WASH SOLUTION.



**GRANULDISK®**

## **GRANULE COMBI® MORE THAN A POT WASHER.**

Granule Combi is not just a pot washer – it's a pot washing *system*. To benefit from its full potential, there are a few details one should keep in mind when designing the kitchen layout.

Over the years, we have tried and tested a number of solutions in close consultation with our suppliers and clients. We would like to share some of our findings with you.

We hope that you find the following information of some use as you specify our Granule Combi.

Feel free to contact us at any time with any additional comments you may have - your feedback is important to us.

Kind regards,  
**GRANULDISK.**



## CONTENTS.

Installation options .....	p.4
Foldable Combi table .....	p.5
Combined crockery & pot wash tabling .....	p.6
Installation examples .....	p.7-8
Docking tables to the machine .....	p.9-10
Roller conveyor or slide bars? .....	p.11
Valuable tips when planning for tabling .....	p. 12

## CHECK OUT THE FREE ONLINE GRANULDISK DESIGNER'S USER PORTAL.

Want online access to tabling production drawings, CAD blocks and many other helpful tips and tricks when planning a professional kitchen with a GRANULDISK wash solution?

Check out our free Designer User Portal and register for instant access.

1. Go to [www.granuldisk.com/design](http://www.granuldisk.com/design)
2. Register a free user profile.
3. Done!

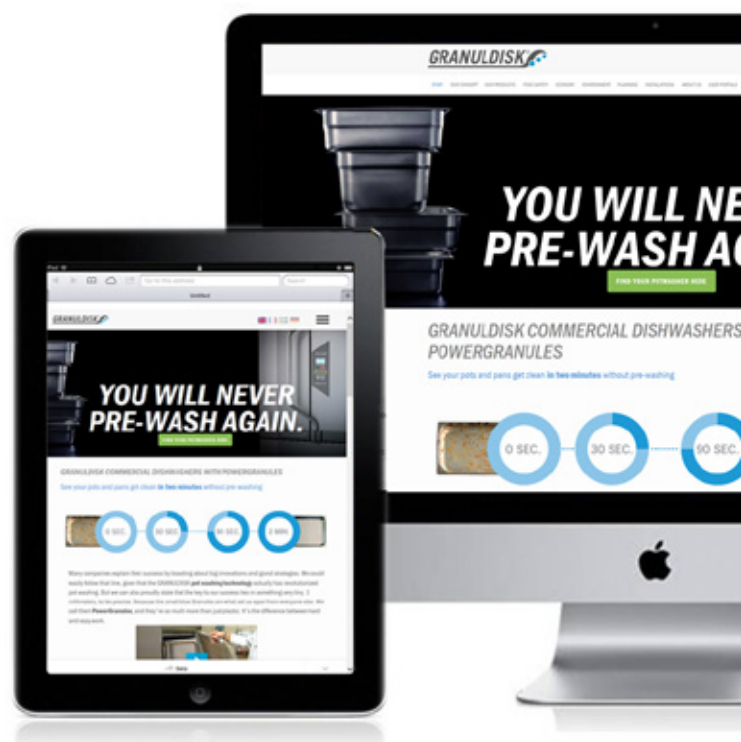

# INSTALLATION OPTIONS.

*Along a wall..*



*... or in a corner?*



## **ALONG A WALL.**

The pass through design makes Granule Combi machines suitable for narrow spaces. No swing-space for doors is needed.

## **IN A CORNER.**

Placing the machine in the corner optimizes space and work flow in small areas.

## **INTEGRATED WITH CROCKERY LOADING STATION.**

Integrating a Granule Combi wash solution in a table system that includes a loading station provides a smooth flow in the kitchen.

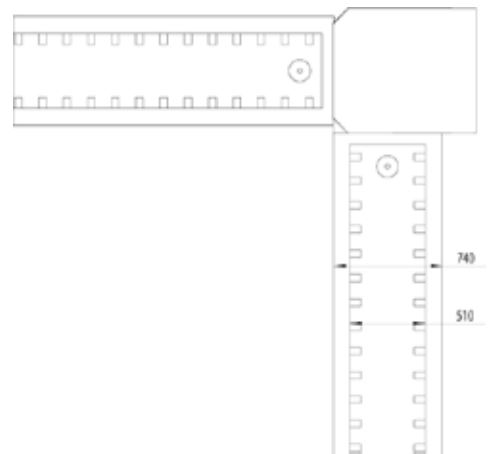
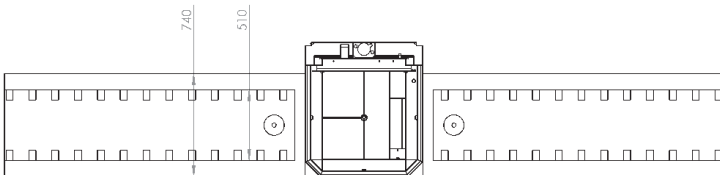

## **Don't forget...**

*Always install Granule Combi with a rinsing station - although the Granule Technology™ is an efficient No Pre-Washing concept, tableware such as plates, cups and cutlery are too sensitive to be washed with PowerGranules and will still need pre-rinsing.*



# FOLDABLE COMBI TABLE.

Ideal for the smaller kitchen area.

- The foldable Combi table can be installed on either side or at the front of the machine. When not in use, the table folds down and hangs vertically along the side of the machine to create more space around it. (see picture below.)

*N.B. The Combi Table is suitable for kitchens with a low crockery flow, as it only allows one crockery basket at a time. For larger quantities, larger inlet and outlet tabling will be necessary.*

- Some of our customers with a machine installed along the wall have chosen to install a Combi table at the front of the machine. The crockery is fed in along the wall and the Combi table is used to support the potwash basket. When the potwashing is done for the day, the table is folded to its vertical position and out of the way.

*E.g. we have this particular solution installed in a kitchen preparing 150 meals/day, washing up to 40-45 crockery baskets and 10-15 potwash baskets a day.*



# COMBINED CROCKERY AND POT WASH TABLING.

## COMBINED TABLE FOR POTS & PANS AND CROCKERY.

The combined table fits both standard crockery baskets (500 x 500 mm) and the Granule Combi standard pot wash basket.

*Please note that the minimum width for the tabling to fit the pot wash basket (GD 102) is 740 mm. To fit standard crockery baskets the minimum width is 510 mm.*

- suitable for installation along wall
- suitable for a corner installation
- can be used as entry and exit table.

## DIMENSIONS.

Some prefer a longer exit table than entry table, as a longer exit area creates a better flow, especially with crockery.

- A 1,600 mm long table is enough to fit 3 crockery baskets or 2 potbaskets.
- A 1,100 mm long table is enough to fit 2 crockery baskets or 1 potbasket.

## CONNECTING INLET OR OUTLET TABLE SYSTEM.

- To connect the combination table (740 mm wide) to a standard crockery table, the edge where the two tables will dock must be narrowed in to a width of 510 mm.

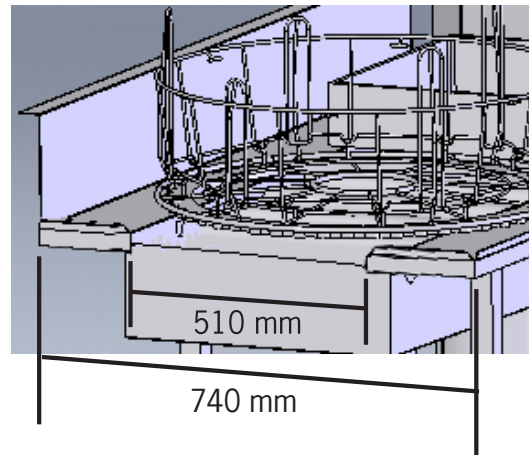

### Tip!

- A** Make sure there is a gap of at least 300 mm between the table leg and the machine to allow for service access as required.
- B** Tables with grill racks underneath are handy for i.e. storing baskets when not in use.

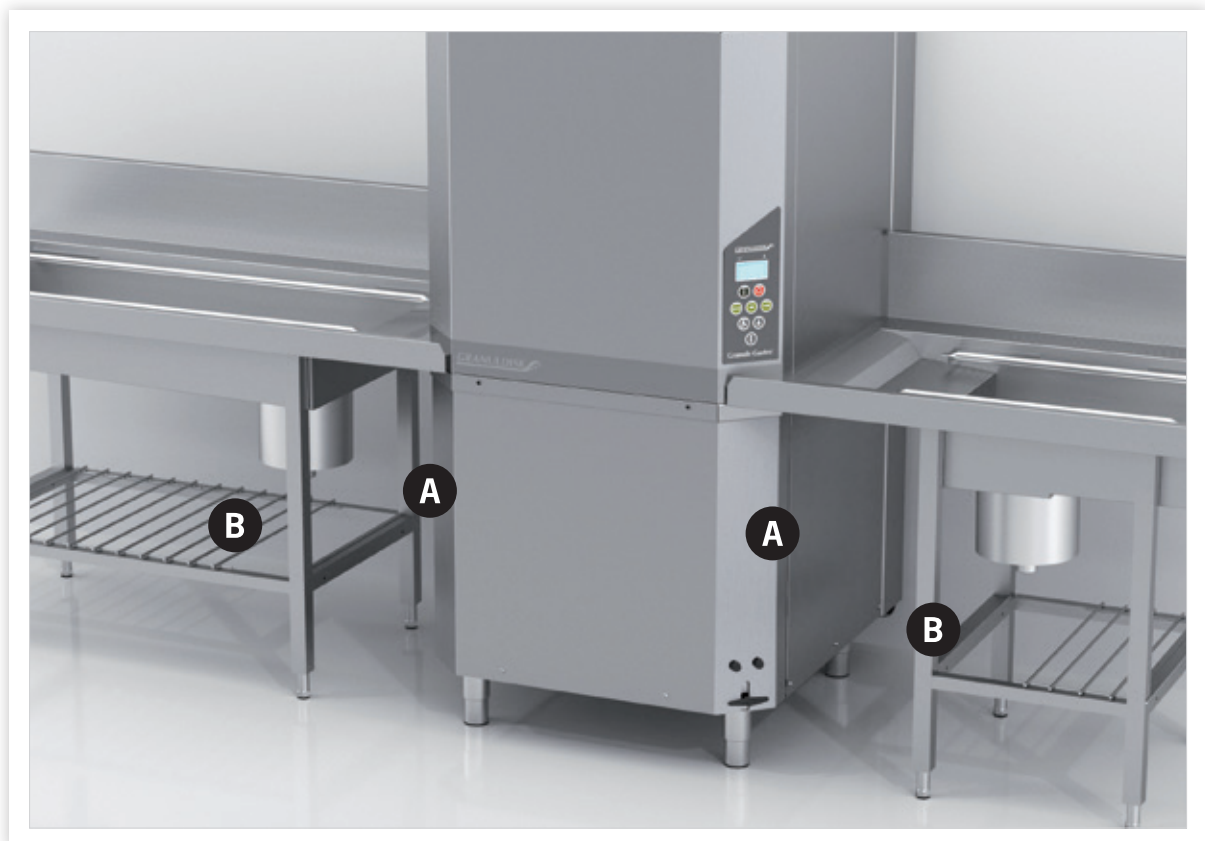

# REAL CASES OF POT WASH TABLING INSTALLATION EXAMPLES.

## 1. TWO-IN-ONE SOLUTION.

- Kitchens serving up to 300 meals/day will manage both crockery and pot wash with a Granule Combi® (depending on crockery mix).
- Also kitchens serving up to 300 hot meals/day with up to 1,000 parallel *Meals On Wheels*\*, will manage both crockery and pots with a Granule Combi® wash solution.

*Kitchens serving more than 300 meals/day will need a separate washing solution for crockery. However, the Granule Combi still is a very smart choice, as it's a handy support during peak-hours and can replace the crockery station altogether in periods with less than 300 eating guests.*

## 2. COMBI MODE USED AS SUPPORT DURING PEAK-HOURS.

- Combined tables used for entry- and exit for crockery and pot wash running in the same line, alternating as the need demands. The Granule Combi in this solution offers an excellent support for the crockery wash during peak-hours.
- Designing the entry table to fit either 3 pot wash baskets or 8 crockery baskets creates an ultimate flow and capacity for a kitchen serving 600 hot meals per day or more where the Granule Combi acts as a support to the crockery line during peak-hours. In periods when serving less than 300 hot meals per day, there's no need to start up the conveyor machine means lower water, energy and detergent cost.

## 3. INTEGRATED CROCKERY LOADING STATION.

- Combination table used as entry tabling (also rinsing station for crockery and scraping station for pots/pans (as in picture 2, right).
- The crockery loading is ideally located on the left side of the combination table.
- When connecting a crockery line to the short end of the table, a dock opening of 510 mm is recommended to allow a 500 x 500 mm basket to slide freely.
- Exit table also features a combination table (crockery/pots+ pans).
- In this particular table solution crockery and pots+ pans run in the same line, alternating as the need demands.
- Length of entry/exit tables should be suited to fit the required capacity for crockery.

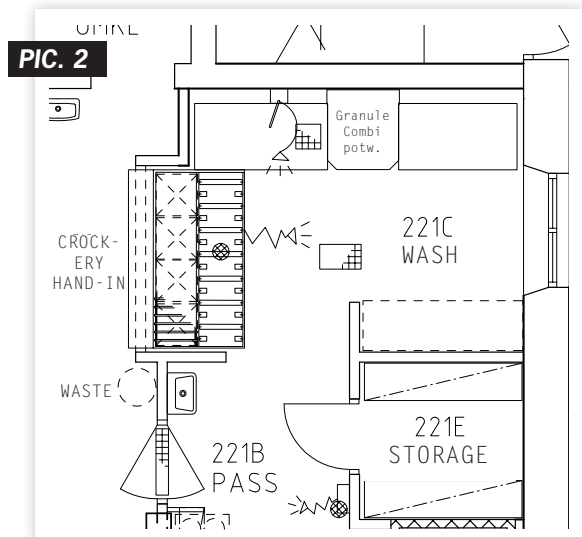

\* Meals produced and delivered to customers outside of the production unit.



# DOCKING TABLES TO THE MACHINE.

(combined crockery/pot wash table)

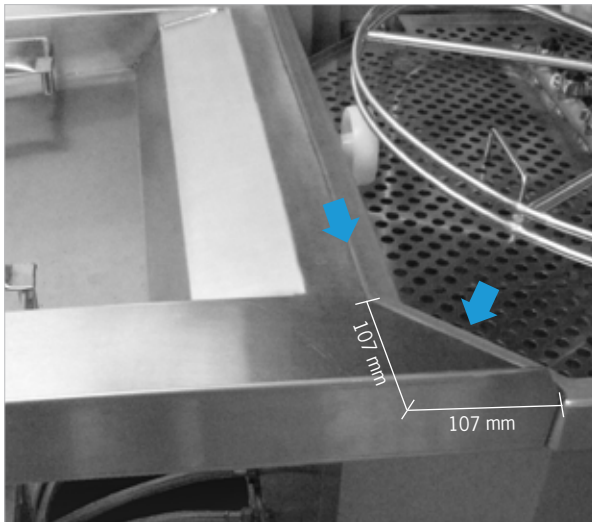

- Make sure the tabling align with and cover the facets of the machine (left).
- Tabling must not be allowed to overlap or hang over the edge into the wash tank, as it will interfere with the rubber seal meant to keep the hood closed tight during washing (see right).

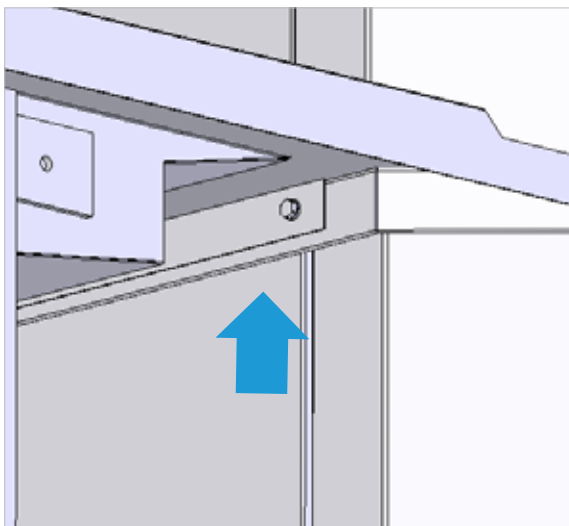
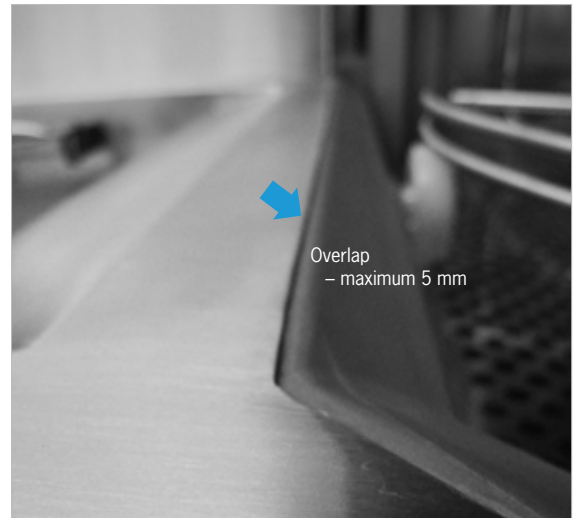

- The table should be secured to the machine using screws and pre-drilled holes.

CC: 500 mm

*The picture shows how the connection of the table to the machine is done by placing both edge to edge and then sealed with silicone.*



## TABLE SOLUTION IN CORNER.

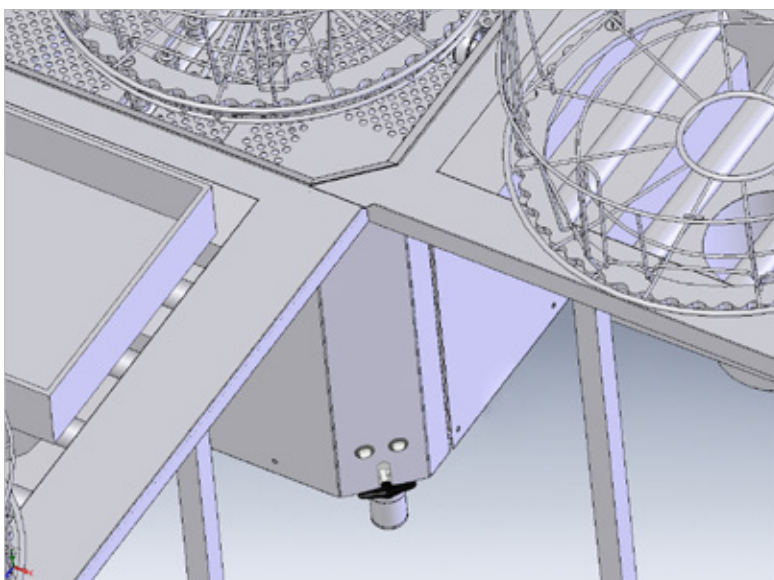

## TABLE SOLUTION ALONG A WALL.

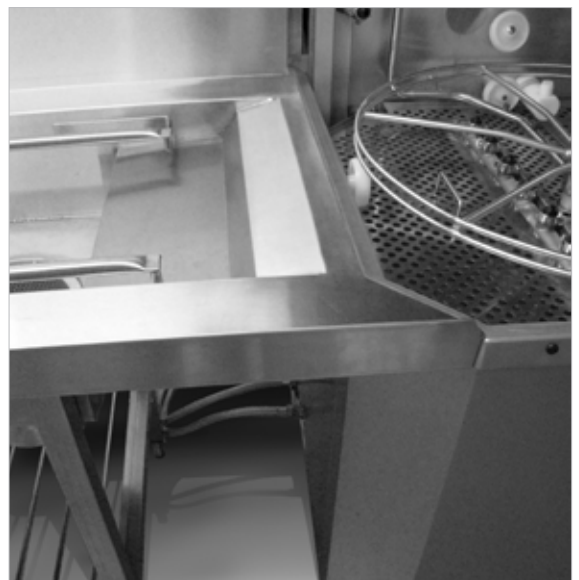



# ROLLER CONVEYOR OR SLIDE BARS?

The table can be fitted with either roller conveyors or slide bars, whichever is preferred.

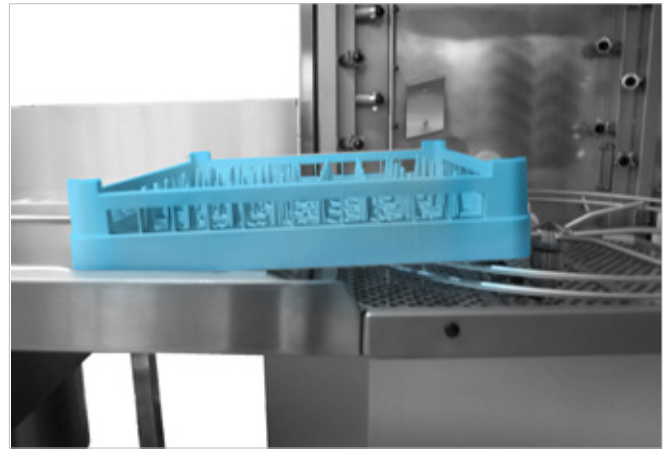
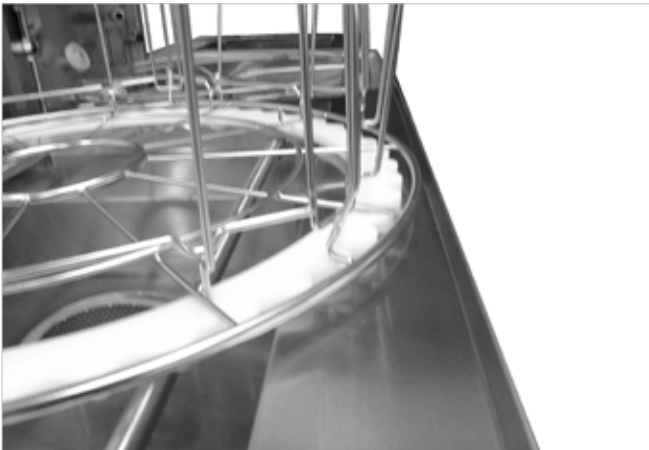
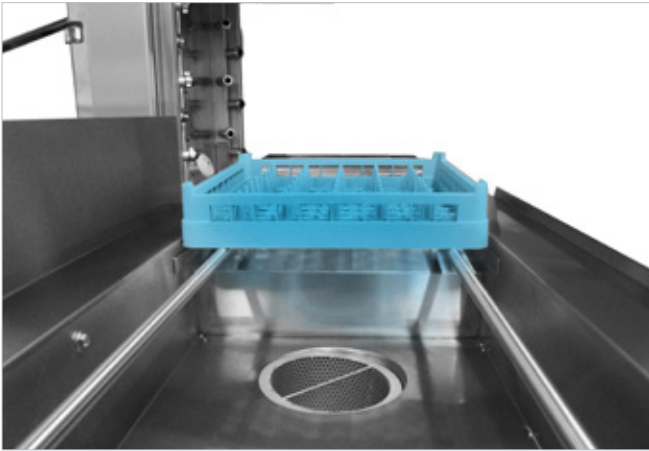

# TIPS & TRICKS WHEN PLANNING TABLING.

## MINIMUM WIDTH.

- The minimum width to fit the Standard Wash Basket is 740 mm
- To fit standard crockery baskets, minimum width is 510 mm.

## CONNECTING TABLING TO MACHINE.

Please avoid hanging the tabling into the wash tank over the rim, as it will interfere with the rubber sealing and will also disturb the hood motion.

*For more detailed information on how to dock tabling to the machine, please see page 8.*

## LET THE CROCKERY TRACK BE 20 MM LOWER THAN THE POTWASH TRACK.

Place slide bars/rolls for the crockery basket path 20 mm lower than the potwash track to allow both basket types glide more smoothly.

## COVER THE FACETS.

Make sure to cover the facets of the machine with the tabling (see picture) to prevent food and water from dripping onto the floor.

## 300 MM SERVICE SPACE.

Make sure to leave at least 300 mm space between the machine and the table legs to enable servicing of the machine without detaching the tables.

## DIRTIES INLET FOR CROCKERY / POTS & PANS INTO THE WASHING AREA.

- Through crockery loading station.  
Make sure the loading station is wide/long enough to fit at least 4 baskets at a time, to allow sorting of the crockery before entering the entry table leading up to the Granule Combi machine.
- Crockery and pots combined.  
Crockery, pots and pans come in trough the same passage. Make sure there is enough space to allow separating the crockery, pots and pans all come in from the same pass. The more organised the in-flow of the items, the more efficient washing-up area.

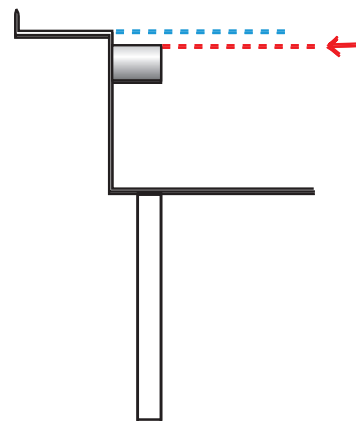
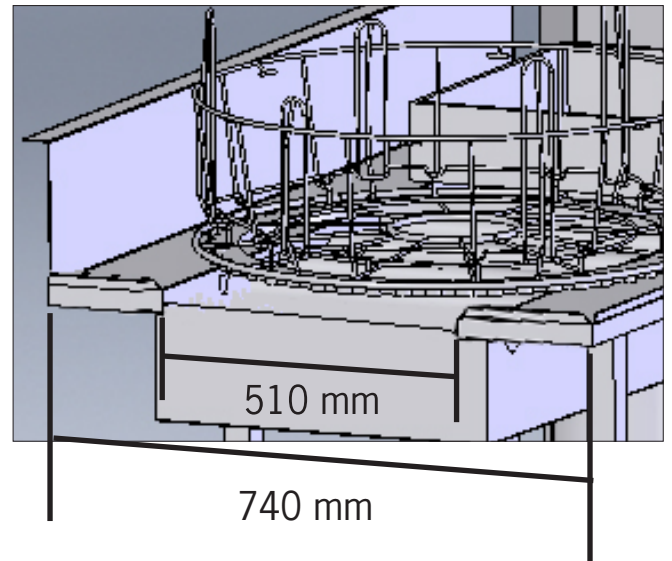

*Positioning of crockery (red) and pot wash (blue) tracks.*

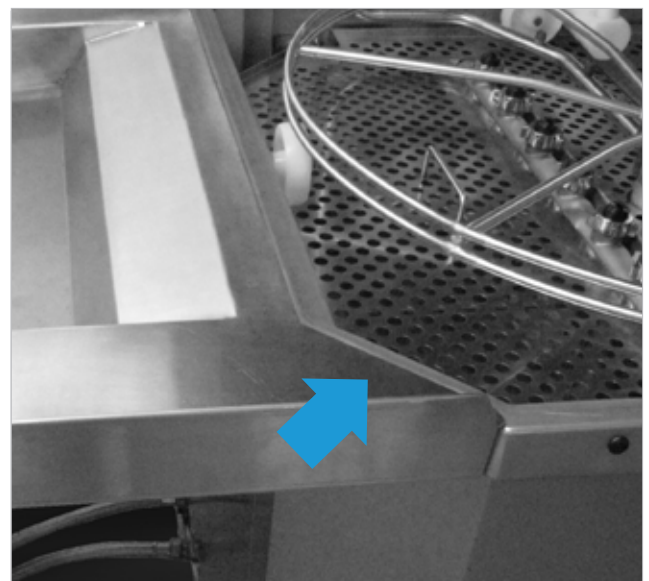

*Cover the facets.*





GRANULDISK, Jägershillgatan 13, 213 75 Malmö, Sweden  
info@granuldisk.com | www.granuldisk.com